

IGNITION

All Models



R.F.I. SUPPRESSION KIT

Kit No.	Models
24 707 01-S	CH/CV22-25 w/variable ignition timing
24 707 03-S	CH/CV17-25 w/fixed ignition timing

Note: Consult factory for KOHLER® Aegis LH/LV engines. Testing still underway to determine if a kit is necessary.

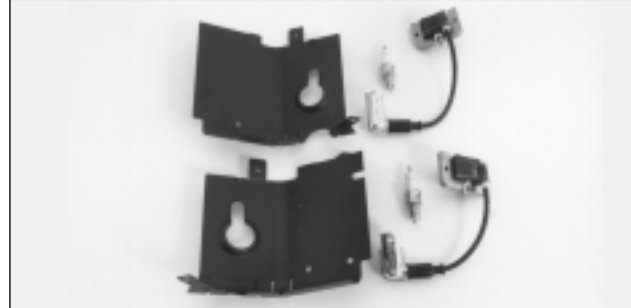

R.F.I. SUPPRESSION KIT

Kit No.	Models
28 707 02-S	TH520-575



SPARK PLUGS

Part No.	Model
63 132 01-S	CS4-12 (NGK)
66 132 01-S	LH630-760, LV625-675, CS4-12 (Champion)
12 132 02-S	CH6, CH/CV11-16/460-492, CH/CV17-26/745, CH20-25 LP, TH520-575, TH520-575 LP
12 132 06-S	CH/CV11-15/493 PRO, CH/CV18-25/730-740 PRO
25 132 08-S	CH/CV14 LP
28 132 01-S	CH/CV17-25 R.F.I.
28 132 02-S	TH520-575 R.F.I.

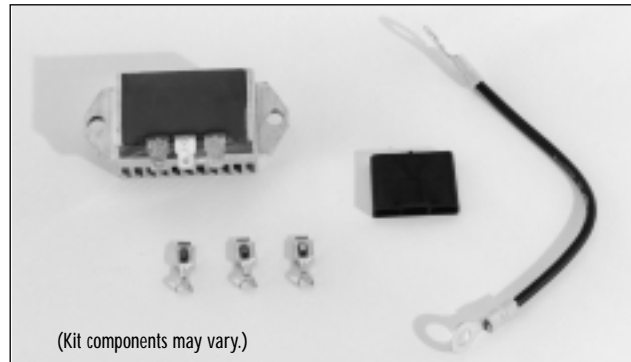

CHARGING SYSTEMS

Part No.	Description	Models
15 Amp		
24 085 01-S	Stator	CH/CV11-16/460-493, CH18-26/730-745
47 085 02-S	Stator	TH520-575
25 755 03-S	Reg.-Rectifier Kit*	TH520-575
41 403 09-S	Reg.-Rectifier	CH18-26/730-745, LH630-760, LV625-675
25 Amp		
28 085 02-S	Stator Kit	CH/CV11-16/460-493, CH/CV17-26/730-745, TH520-575, LH630-760, LV625-675
54 755 03-S	Stator/Reg. Rect. Kit	CH/CV17-26/730-745
25 755 23-S	Reg.-Rectifier Kit	** (Shown)

*Inc. reg.-rectifier, screws (2).

**Converts old 25 amp regulator/rectifier (25 403 01-S or 25 403 04-S) to new 25 amp regulator/rectifier (25 403 05-S) on all models. (Some specs may require extra parts when upgrading from 15 amp system.) Includes regulator/rectifier, terminals (3), lead, connector block.

METAL CHOPPER GRASS SCREEN KITS

Kit No.	Models
28 755 14-S	TH520-575

Replaces plastic screen. Includes plastic stylized guard, along with inserts and insert tool for attaching to blower housing.



Kit No.	Models
12 755 78-S	CV11-16/460-493

Replaces plastic screen on recoil start engines. Includes outer-edge guard and blower housing.



Kit No.	Models
24 755 79-S	CH/CV17-26/730-745

Replaces plastic screen, or can replace "crowned" metal screen on engines below serial number 25284185567. A new blower housing is required if replacing a plastic screen.*

Note: When installing metal screen on an "open" application, guard kit 24 755 94-S is required.

*Due to blower housing variations, consult Kohler factory. Based on the spec number of your engine, the corresponding blower housing can be determined.

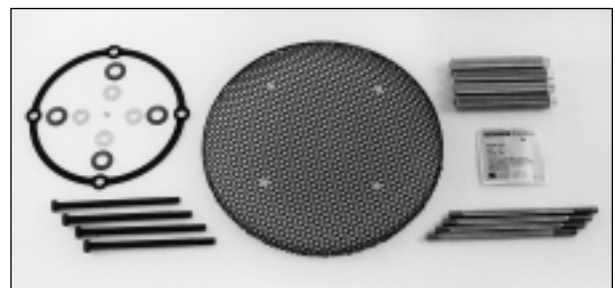

IGNITION

All Models

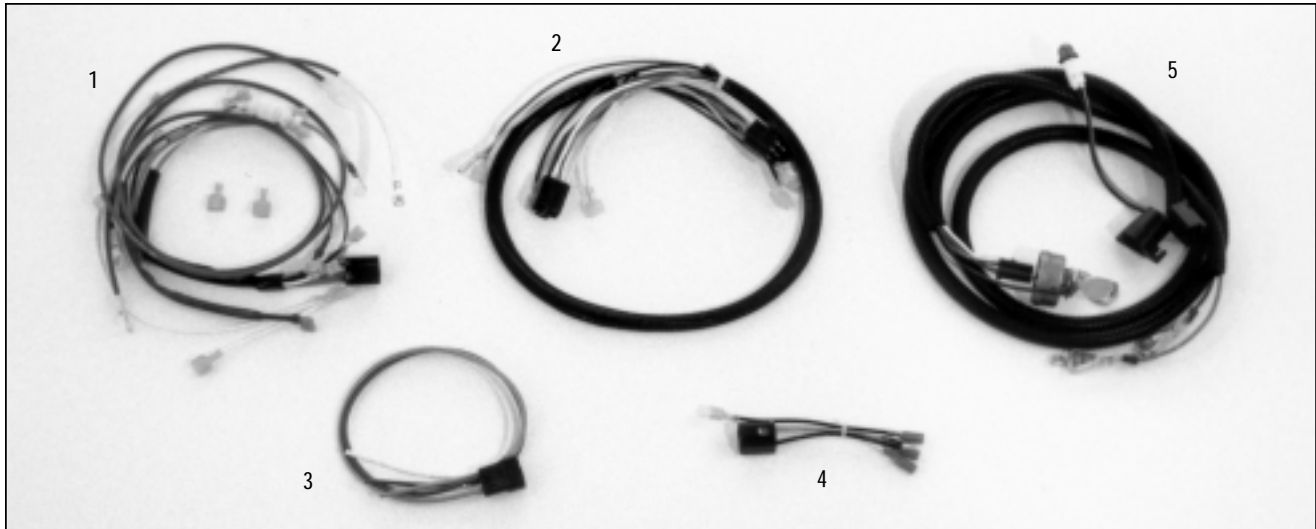

WIRING HARNESSSES

Part No.	No. Leads	Lead Length	Connector	Models	Item
54 755 02-S	*	34" longest	Numerous	CH/CV17-25/730-740	1
66 176 18-S	8**	36" longest	25 155 06 (Female), 48 155 01 (Male)	LH630-750	2
52 155 08-S	2	18" all	52 155 04 (Female)	Various	3
52 155 09-S	3	18" all	237088 (Female)	Various (shown)	3
25 155 07-S	5	18" all	25 155 06 (Female)	Various	3
25 155 09-S	5	18" all	25 155 06 (Female), 48 155 01 (Male)	Various	3
25 176 02-S	6***	75" longest	25 155 06 (Female), 48 155 01 (Male)	C11-16/460-493, C17-25/730-740 LH630-675, LV625-675	3
63 176 01-S	6****	5" longest	48 155 01 (Male)	CS8.5-12	4
24 176 114-S	*****	42" longest	25 155 06 (Female), 48 155 01 (Male)	All EFI	5

* Includes universal harness, duplex lead harness, Oil Sentry™ lead, 20 amp B+ lead, 25 amp B+ lead with Connector 25 155 03-S, (2) Terminals 15 452 10-S, and instructions.

** Can be used as a general 36" extension to basic wire harness.

*** Includes equipment ground lead for between keyswitch and engine block.

**** Used to create remote-mount keyswitch (use Keyswitch 25 099 04-S). Also order Harness 25 176 02-S above.

***** Allows for isolation of EFI engine from application to diagnose location of problem. Numerous leads.



STARTER SOLENOIDS

For internally grounded engines with keyswitches. Not for use with solenoid shift starters.

Part No.	Description	Models
25 435 02-S*	Internally grounded	CH/CV11-16/460-493

*Waterproof



SEALED FUSE HARNESS/HOLDER

Part No.	Models
54 755 13-S	All

Converts standard harness/fuse holder to a sealed version to prevent moisture, dirt, etc., from penetrating. Ideal for pressure washers or applications in corrosive environment. Includes 30 amp fuse.

IGNITION

All Models

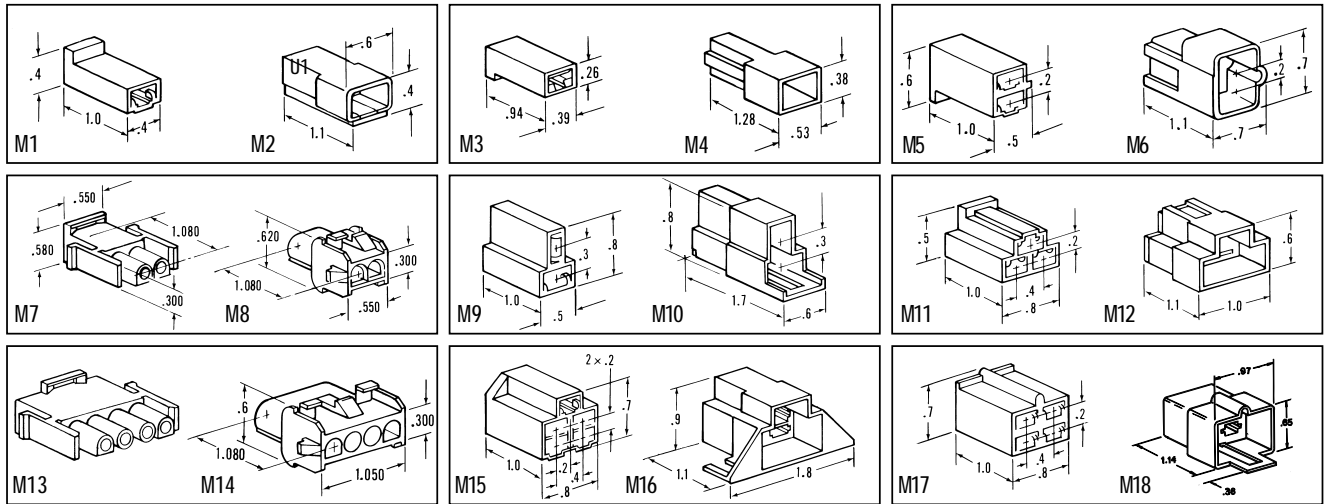

MATED (M) CONNECTORS

Description	Connector Item	Connector Part No.	Uses Female Terminal (See Below)	Connector Item	Connector Part No.	Uses Male Terminal (See Below)
1 Wire	M1	277563-S	Item 5, 6	M2	15 155 01-S	Item 4
1 Wire	M3	25 155 04-S	Item 5, 6	M4	25 155 03-S	—
2 Wire	M5	41 155 03-S	Item 5, 6	M6	52 155 04-S	Item 4
2 Wire	M7	47 155 14-S	—	M8	47 155 13-S	—
2 Wire	M9	48 155 02-S	Item 5, 6	M10	48 155 03-S	Item 4
3 Wire	M11	236473-S	Item 5, 6	M12	237088-S	Item 4
4 Wire	M13	12 155 03-S	—	M14	12 155 02-S	—
5 Wire	M15	48 155 01-S	Item 5, 6	M16*	25 155 06-S	Item 4
4 Wire	M17	41 155 02-S	Item 5, 6	M18	12 155 10-S	Item 4

* Mounting screw slots on M16 are 1.328" center to center.

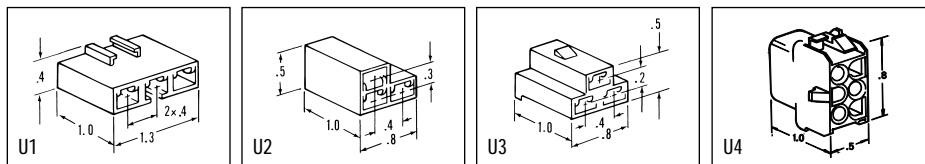

UNMATED (U) CONNECTORS

Description	Connector Part No.	Connector Item	Uses Terminal (See Below)
3 Wire	236602-S	U1	Item 5, 6
3 Wire	237429-S	U2	Item 5, 6
3 Wire	52 155 06-S	U3	Item 5, 6
6 Wire	12 155 09-S	U4	—

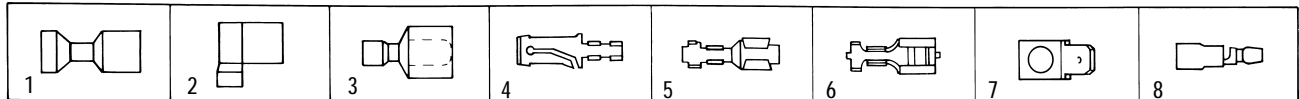

TERMINALS

Size	Part No.	Type	Code	Item	Type	Code
3/16" Flat	25 452 11-S	F.I.F.	S	1	F.I.F. = Fully Insulated Female	S = Straight push on tab
3/16" Flat	25 452 12-S	F.I.F.	F	2	F.I.M. = Fully Insulated Male	F = Flag push on tab
1/4" Flat	25 452 07-S	F.I.F.	S	1	L.F. = Locking Female	U = Uninsulated
1/4" Flat	15 452 01-S	F.I.M.	S	3	L.M. = Locking Male	
1/4" Flat	52 452 01-S	L.M.	S, U	4	M = Male	
1/4" Flat	25 452 01-S	L.F.	S, U	5		
1/4" Flat	25 452 06-S	L.F.	S, U	6		
1/4" Flat	12 452 02-S	M	45°, U	7		
1/8" Round	25 452 17-S	F.I.M.	S	8		